



DOMINATORPLUS

G3625 Radiant Chargin

Key features

- 2 x 8.6kW cast iron burners
 - Quick heat up, reduced waiting time
- Reversible, angled, heavy duty cast iron brander bars
 - Delivers even heat across entire cooking surface
- Full width cooking area
 - Maximum output
- Independently controlled burners
 - Vary heat across unit if required or even turn one side off during quieter periods
- Removable stainless steel surround
 - Ensures adjacent equipment remains spatter free
- Grease collection tray at front of unit
 - Catches and contains grease and fat
- Full width debris collection tray below unit
 - Catches all grease and debris
- Large capacity grease collection container
 - Easy to remove and empty during service
- Cast iron burners with variable control / turndown
 - Ensures chargin is at the desired temperature
- Laser-etched control icons
 - Permanent, indelible markings

Accessories

- Griddle plate
- V bars
- Fixed stand
- Factory fitted, adjustable castors
- Fixed installation kit



Similar Models

- G3425 radiant chargin
- G9460 radiant chargin
- G9490 radiant chargin
- E3625 electric chargin

Radiant Charngrill

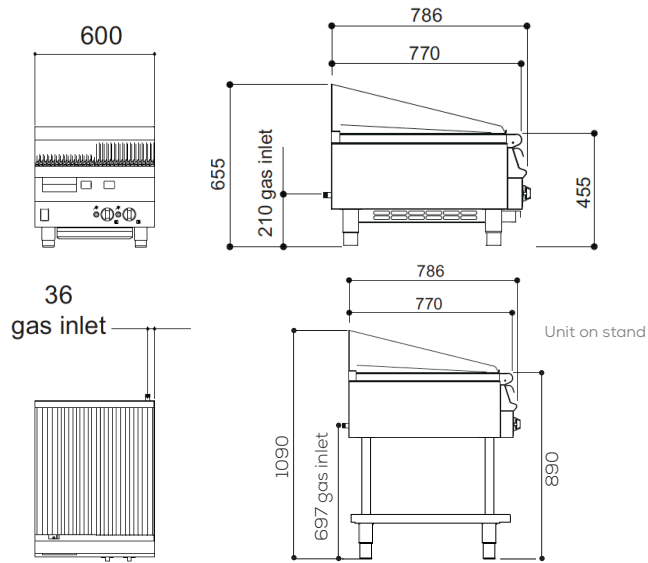

Measurements *in mm*

Unit on castors is the same hob height

Installation notes

Adequate ventilation must be provided to supply sufficient fresh air for combustion and to allow easy removal of any such products that may present a risk to health. Please consult current legislation for details that relate to specific locations.

Install unit on a level, fireproof surface in a well-lit, draught free position. If floor is made of a combustible material, local fire requirements must be checked to ensure compliance.

A clearance of 150mm should be observed between appliance and any combustible wall.

Specification details

Total rating (natural and propane - kW - Nett)	17.2	
Total rating (natural and propane - btu/hr - gross)	64,573	
Inlet size (natural and propane)	3/4" BSP	
Flow rate - natural (m ³ /hr)	1.69	
Flow rate - propane (kg/hr)	1.34	
Inlet pressure (natural and propane - mbar)	20 / 37	
Operating pressure (natural and propane - mbar)	15 / 37	
Cooking area (w x d - mm)	560 x 630	
Number of burners	2	
Number of brander bars	6	
Weight (kg)	143	
Weight on stand (kg)	165	
Packed weight (kg)	162	
Packed dimensions (w x d x h - mm)	650 x 1000 x 650	
GTIN numbers	Nat Gas	LPG

